



DELIVERING BETTER DRILLING OUTCOMES WITH RIG FLOOR AUTOMATION

REDUCE DRILLPIPE DAMAGE & INCREASE TORQUE EFFICIENCY IN UNCONVENTIONAL WELLS

The drilling landscape is changing as automation and mechanization create opportunities to further enhance safety and performance, while meeting the aggressive parameters required for deeper wells with longer laterals.

Empowered by the Helmerich & Payne legacy of domain expertise and innovative technology, the HexGrip™ 120 automated floor wrench, combined with additional rig floor mechanization enhancements, move modern well programs forward to new performance milestones in the industry's performance journey.

THE INDUSTRY'S PREMIERE HIGH TORQUE SOLUTION FOR THE UNCONVENTIONAL DRILLING MARKET

The HexGrip 120 automated floor wrench offers the consistently high makeup and breakout torque needed to ensure connection integrity. Factoring the strain extra torque can have on the box, the HexGrip 120 uses six contact points on the upper and lower arms, reducing the force needed to make and break connections, all safely controlled remotely from the driller's cabin. In addition to process efficiency, remote diagnostic capabilities track and record connection data, enabling a detailed representation of connection integrity's impact on drilling practices and continuous improvement.



**A MAJOR OPERATOR
IN WEST TEXAS SAW
A 90% REDUCTION IN
TONG USAGE AFTER
THE HEXGRIP™ 120
WRENCH WAS
INSTALLED.**



Case Study
(click to view)

WHAT WILL HEXGRIP 120™ MEAN TO YOUR WELL PROGRAM?

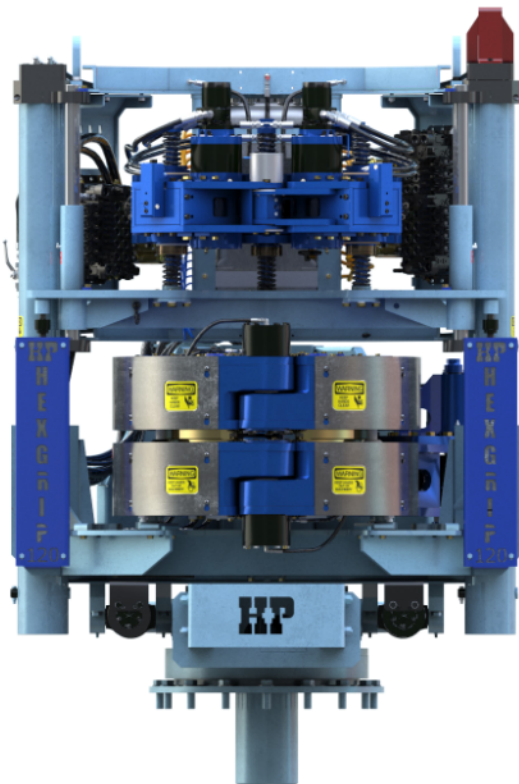
▶ FEATURES ◀	▶ BENEFIT ◀	▶ OUTCOME ◀
100,000 ft-lb Makeup Torque	Efficient and consistent pipe connections	Accurate and consistent makeup torque helps mitigate challenges associated with under torqued connections such as drillstring backoffs and over-torqued connections.
120,000 ft-lb Breakout Torque	Improved trip times	High breakout torque and improved gripping will reduce drillpipe wear associated with slipping on the tool joint and reduce tong events by up to 90%.
<1% Makeup Torque Variance	10x less torque variance	With precise torque consistency--more consistent well delivery can be achieved.
360° Six-Point Grip	Less force on drill pipe	The power and precision of the torque in conjunction with the radial contact reduces slippage and pipe distortion--prolonging pipe life and integrity.
Remote Connected	Relocation of control to the driller's cabin	Moving control to the driller cabin significantly reduces the human exposure on the rig floor and improves overall efficiency.
Data Logging	Automated logging of applied torque	Torque data from the HexGrip 120 wrench can be used to evaluate drilling specifications and practices that contribute to the optimization of future wells.
Compact Design	38% smaller and 40% lighter than alternative high-spec floor wrenches	The industry leading FlexRig fleet revolutionized rig move efficiency. Now, the HexGrip 120 wrench provides industry-leading floor wrench capabilities and a minimal footprint without compromising the efficiency gains achieved with our rigs.

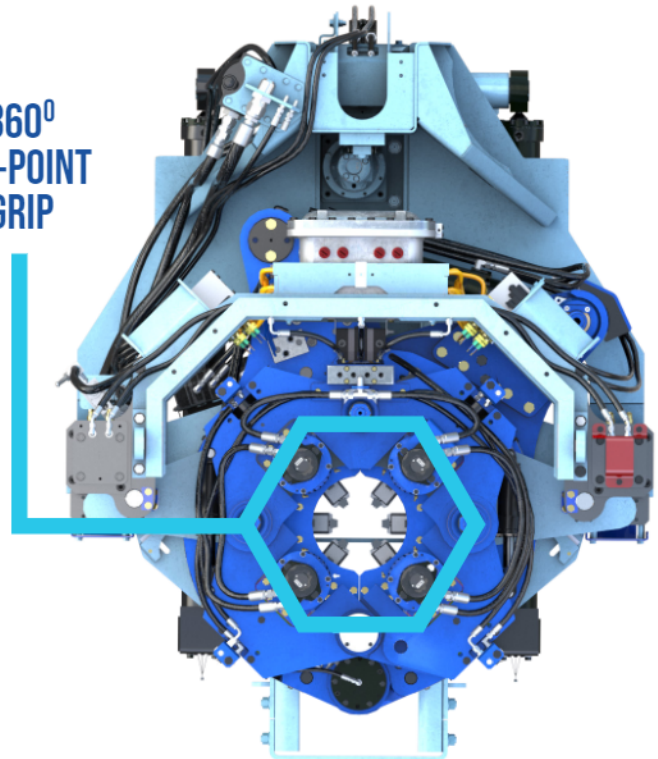

360°
SIX-POINT
GRIP



HEXGRIP™ 120 AUTOMATED FLOOR WRENCH TECHNICAL SPECIFICATIONS

Makeup Torque	100,000 ft-lb / 135,582 Nm
Breakout Torque	120,000 ft-lb / 162,698 Nm
Die Contact Points	6 per arm (360° of contact)
Force / Die	56,550lbs
Clamping Force	20,000psi
Displacement of Box	0.007in
Minimum Tool Joint Diameter	3½" / 89 mm
Maximum Tool Joint Diameter	9" / 229 mm
Minimum Working Dimension [100" arm delivery]	75" / 1,905 mm
Maximum Working Dimension [100" arm delivery]	103" / 2,616 mm
12" of vertical travel for spinner to accommodate varying pipe sizes and tool joints	
Precise torque logging automatically recorded for easy reporting	
Remote operated from driller's cabin	

ENHANCED RIG FLOOR MECHANIZATION

The labor involved in manually placing and pulling slips is not only a physical hardship, it places crew members in a high-risk area near the well center. Because H&P's Retractable Slip Lifters are inset into the rig floor, the top drive can now drill all the way down, creating a seamless transition between drilling and tripping. Safely controlled from the driller's cabin, HSE exposure is reduced by removing additional rig crew presence from well center, while streamlining the overall process to deliver a more consistent outcome.

Rig Floor Automation provides safety and consistency through automation controls and also through the simplicity of enhanced traction control floor mats. These custom-designed mats utilize a combination of raised buttons for traction and are durable enough to withstand even oil-based fluids that commonly affect traditional matting. High-risk areas are identified through color-coded zones on the mats to help mitigate hazards to crew members. Modularity ensures a quick change-out if needed, without incurring downtime.



CONTACT US

For more information on how our Rig Floor Automation package can help you achieve better drilling outcomes, contact an H&P sales representative today or contact us through our website at helmerichpayne.com/contact.

It's time to follow through on your drilling performance potential.

PAST PERFORMANCE IS NOT A GUARANTEE OF FUTURE RESULTS. ANY STATEMENTS REGARDING PAST PERFORMANCE ARE NOT GUARANTEES OF FUTURE PERFORMANCE AND ACTUAL RESULTS MAY DIFFER MATERIALLY.
HPFS021